



UNIVERSITY *of* DUBUQUE





John and Alice Butler Hall

Technical Rider

Revised August 2018

HERITAGE CENTER STAFF

Thomas J. Robbins

Executive Director

Office: 563-589-3325

E-Mail: TRobbins@dbq.edu

Victoria Molle

Director of Audience Services

Office – 563-589-3432

E-Mail: VMolle@dbq.edu

Randy Schultz

Technical Director

Office - 563-589-3580

Cell - 262-224-2975

E-Mail: RSchultz@dbq.edu

Korissa Clark

Office Manager

Office – 563-589-3325

E-Mail: KClark@dbq.edu

University address: 2000 University Ave.
Dubuque, IA 52001

Heritage Center address: 2255 Bennett St.
Dubuque, IA 52001

BUILDING ACCESS / LOADING DOCK

Main entrance is located off of Bennett Street.

Loading dock / stage door are on the west side of the building off of McCormick Street.

The loading dock leveler is adjustable from 3 feet to 5 feet.

No Shore Power available.

Access code will be giving upon arrival.

Vehicles are not allowed to remain in the loading dock area once unloaded, there is parking available in University lots or on street parking.



University of Dubuque Campus Map

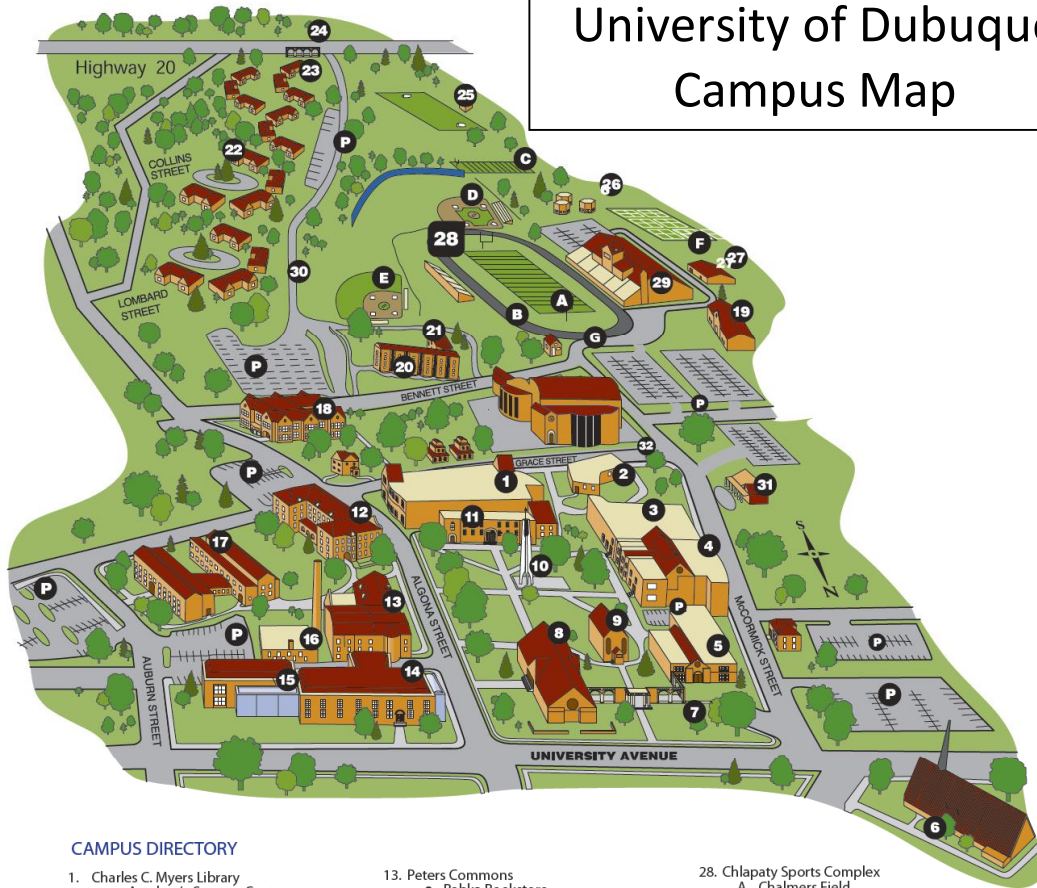

CAMPUS DIRECTORY

1. Charles C. Myers Library
 - Academic Success Center
 - Learning Assistance Center
 - Sylvia's Common Ground
 - Coffee Shop
 2. Smith Hall
 - Business/Finance
 - Education
 - Human Resources
 - Physical Education/HWR
 - Safety/Security
 3. Stoltz Sports Center
 - Athletic Administrative Offices
 - Jon Davison Court
 - Physical Education Offices
 4. McCormick Gymnasium
 5. Jackaline Baldwin Dunlap Technology Center
 - CGIM
 - CIS
 6. Westminster Presbyterian Church
 7. Steffens Colonnade
 8. Blades Hall
 9. Alumni Hall
 10. William C. Laube Memorial Bell Tower
 11. Van Vliet Hall
 - Academic Affairs Office
 - Advancement Offices
 - Alumni Relations
 - Campus Post Office
 - English
 - History
 - Political Science
 - Print Room/Mailroom
 - Speech Communication
 - UD for Kids
 12. Severance Hall
 - Aviation
 - Philosophy
 - Psychology
 - Religion
 - Seminary Admission
 - Seminary Dean's Office
 - Seminary Faculty and Staff Offices
 - Sociology/Criminal Justice
 13. Peters Commons
 - Babka Bookstore
 - Campus Ministry
 - Career and Life Services
 - Dining Hall
 - Food Service Offices
 - International Studies
 - Student Housing
 - Student Life Office
 - Student Offices
 - Student Union/Underground
 14. Science Center – Goldthorp Hall
 - Mathematics
 - Nursing
 - Sciences
 15. Science Center – Mary Chlapaty Hall
 - Mathematics
 - Sciences
 16. Heating Plant
 17. Aitchison Residence Hall
 18. Charles & Romona Myers Center
 - Business Faculty Offices
 - Cashier
 - College Admission
 - M.A.C. Graduate Offices
 - M.B.A. Graduate Offices
 - President's Office
 - Romona's Boutique
 - Registrar
 - Student Accounts
 - Student Financial Planning
 - Wendt Center
 - University Relations
 19. Mercer Birmingham Building
(ROTC and Athletic Coaches' Offices)
 20. Cassat Residence Hall
 21. Donnell Residence Hall
 22. Seminary Village
 23. University Park Village
 24. Conlon Colonnade
 25. Oyen Soccer Field and Press Box
 26. Potterveld Apartments
 27. Maintenance/Custodial Offices
 28. Chlapaty Sports Complex
 - A. Chalmers Field
 - B. Miller Track
 - C. Football Practice Field
 - D. Baseball Field
 - E. Softball Field
 - F. Tennis Courts
 - G. Ticket Booth
 29. Chlapaty Recreation & Wellness Center
 30. University Parkway
 31. University Daycare
 32. Heritage Center
 - Aitchison/Welch Rehearsal Room
 - Babka Theatre
 - Campus Post Office
 - Charles and Elizabeth Bisignano Gallery
 - DB&T Fine and Performing Arts Suite
 - Farber Box Office
 - John and Alice Butler Hall
 - Linda Chlapaty Music Education Center
 - Sparty's Convenience Store
 - Straatmeyer Rehearsal Room
 - Susan Magill Smith Suite
 - Student Activities
 - International Students
 - Multicultural Services
- P. Parking Areas
 Visitor parking is available in the lot next to McCormick Street, by the football field, and across from Severance Hall. Before parking in these areas, visitors must obtain a parking permit from the Security Office.

SEATING

Pit

Section 100 - ~50 free standing chairs

Main level

Section 101 – 53 Seats (1 seat is removable for ADA seating)
(1 seat is ADA accessible)

Section 102 – 191 Seats (3 seats are removable for tech table)
(3 seats are removable for ADA seating)
(2 seats are ADA accessible)

Section 103 - 53 Seats (1 seat is removable for ADA seating)

Vineyard House Left

Section 104 - 89 Seats

Mezzanine

Section 105 - 112 Seats

Vineyard House Right

Section 106 – 84 Seats (1 seat is ADA accessible)
(1 seat is removable for ADA seating)

Balcony

Section 201 - 45 Seats

Section 202 - 57 Seats (6 seats are removable for ADA seating)
(2 seats are ADA accessible)

Section 203 - 45 Seats

Section 204 - 63 Seats

Section 205 - 103 Seats

Section 206 - 63 Seats

MAIN FLOOR

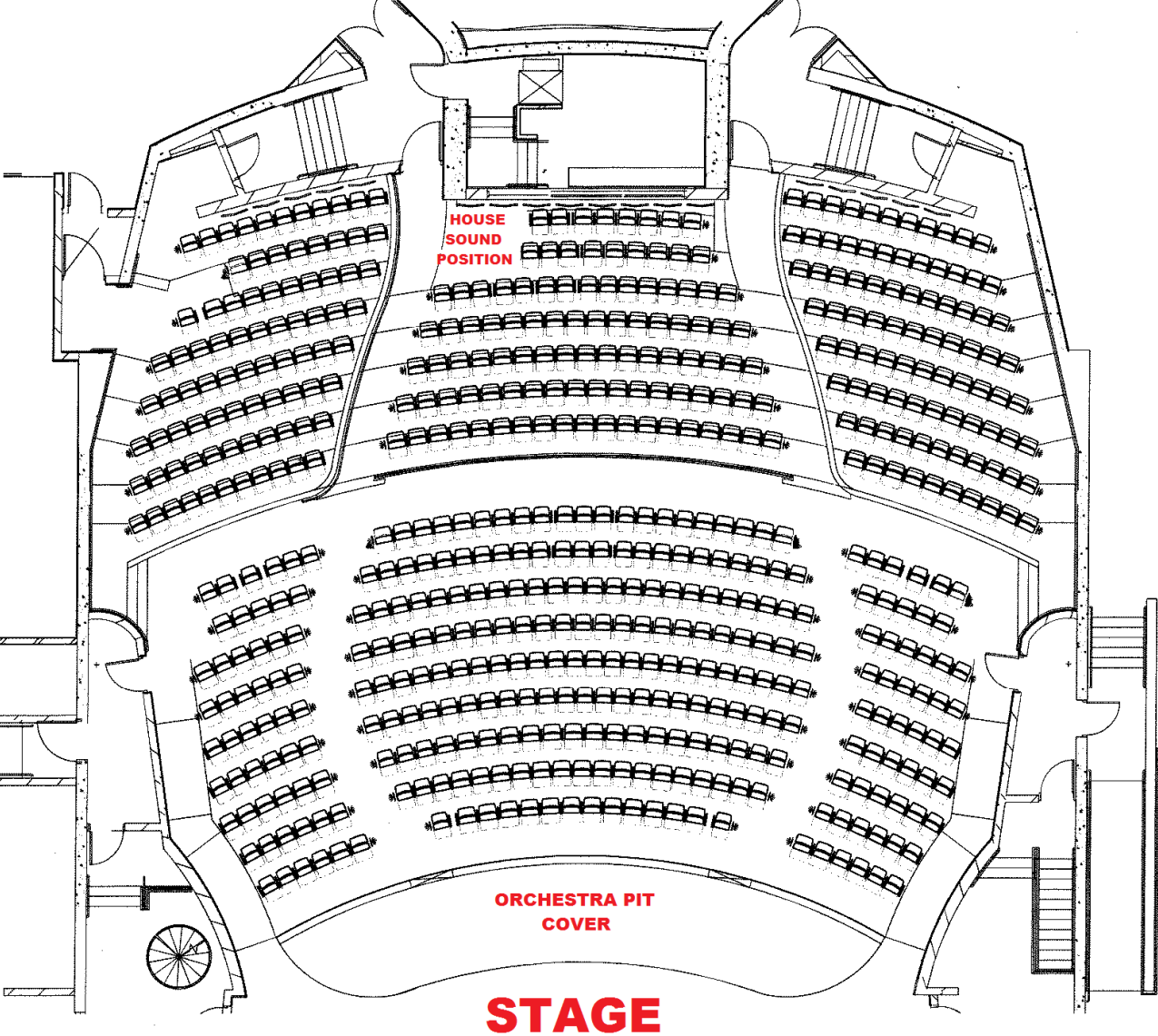

BALCONY

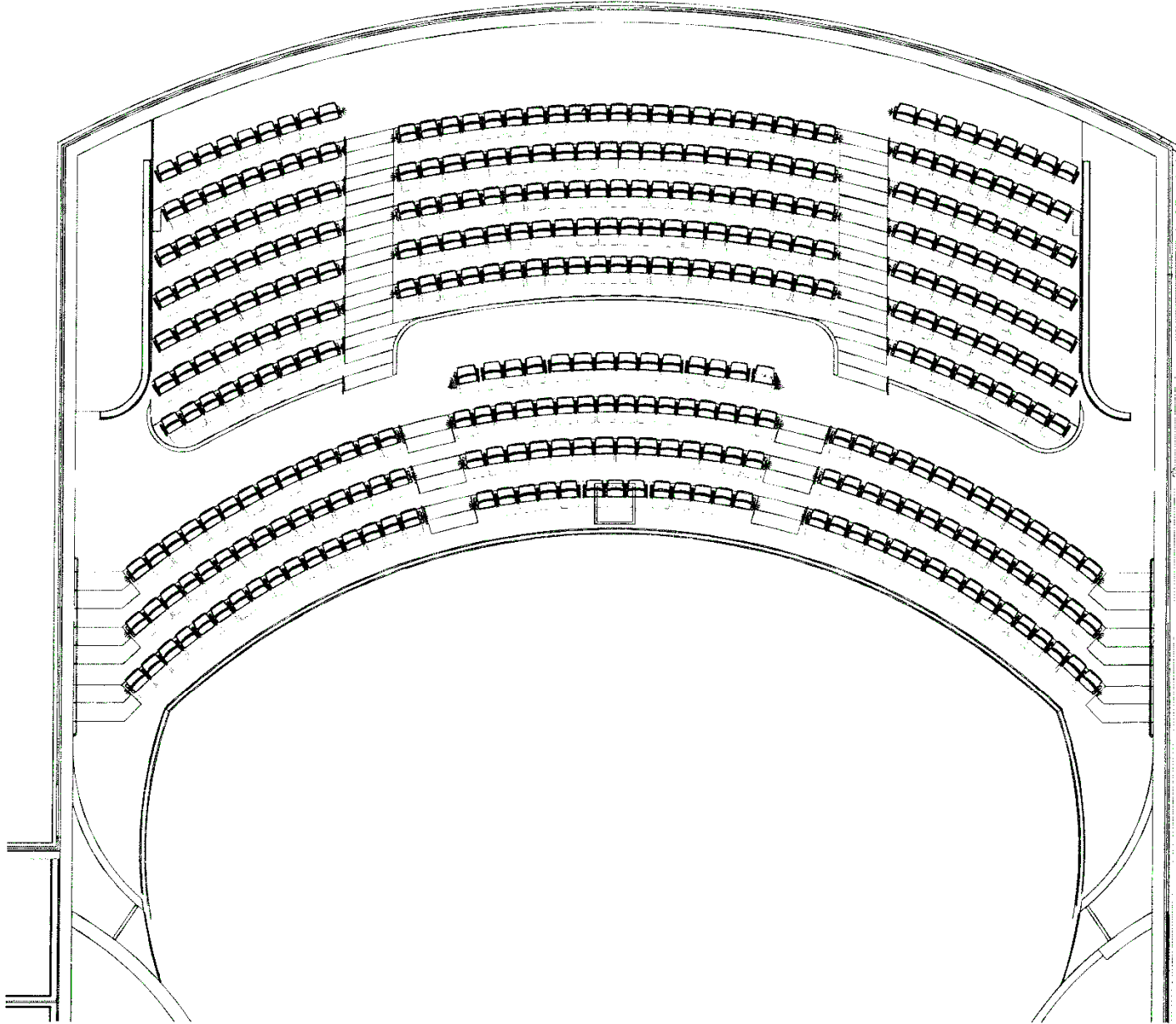

STAGE DIMENSIONS

Dimension	Distance Imperial
Proscenium Width	52'-0"
Proscenium Height	27'-11"
Plaster Line to US Wall	39'-8"
Stage Width (Wall to Fly Rail)	89'-11"
Pit @ Onstage edge to US wall	49'-0"
Pit @ Downstage edge to US wall	60'-11"
Stage Deck to Grid	71'-1"
Deck to pin Rail SL	27'-8"
Deck to Pin Rail SR	27'-8"
Pin Rail to Pin Rail	70'-9"
Height of stage from main floor	3'-0"

RIGGING

Electrics

The First Electric is on a motorized lineset

The 2nd, 3rd, and 4th are double purchase linesets

There are 4 grid drop boxes, 2 SL 2 SR with 4 Circuits that can be added to any lineset

Orchestra Shell

3 Orchestra clouds are on Motorized Linesets

General

All general purpose Linesets are single purchase

2nd, 3rd, and 4th Electrics are Double Purchase

1st Electric and Orchestra Clouds are automated assist

Spot rigging load limits

Rigging Loft Beams - 300 pounds per linear foot

Rigging Head Block Beams - 2500 pounds per linear foot

Gridiron Surface – Will be addressed on an event by event basis, bridle rigging required in most cases.

Pin Rail Pipe - 500 pounds per linear foot in an upward direction.

Front of House Rigging Beam - 1000 pounds per linear foot.

All fixed lighting positions (box booms, black box outriggers, ante-pros, balcony rails) - 25 pounds per linear foot.

Notes

- Walkable Grid over the fly tower
- Catwalk access to the 4 FOH positions, Box Booms, and follow spot booth
- Pin rail SR and SL for spot rigging accessible from the 3rd floor
- Fly operation is located at the stage level on the Stage Right side

STAGE FLOOR

The stage floor is rubber sleeper sprung covered with Masonite topped plywood painted satin black.

The curved orchestra pit filler platforms manufactured by Staging Concepts. They are also topped with Masonite topped plywood painted black. Penetrations are not allowed in any locations.

SOFT GOODS

Drape	Quantity	Material	Color	Finished Size Wide x Tall	Fullness	Top Finish	Bottom Finish
Main Curtain	2 pcs	"Majestic" 25oz	Copper	34'-6" x 35'-6"	100%	Webbing, grommets & snap hooks; 12" on center	Pocket & chain
Main Border	1	"Majestic" 25oz	Copper	69'-0" x 14'-0"	50%	Webbing, grommets & ties; 12" on center	Pocket & chain
Legs	8	Plateau IFR Velour	Black	12'-0" x 30'-6"	Flat	Webbing, grommets & ties; 12" on center	Pocket & chain
Borders	4	Plateau IFR Velour	Black	69'-0" x 12'-0"	Flat	Webbing, grommets & ties; 12" on center	Pocket & chain
Full Stage Black	1	Plateau IFR Velour	Black	69'-0" x 35' 6"	Flat	Webbing, grommets & ties; 12" on center	Pocket & chain
Cyclorama	1	Muslin / Seamless	White	69'-0" x 35' 6"	Flat	Webbing, grommets & ties; 12" on center	Pipe Pocket

PROJECTION

Drape	Quantity	Material	Color	Finished Size	Mounting	Portable
Screen	1	Front Projection	White	22'-0" wide x 13-9" tall	Line Set Only	Yes (Line Set)
Screen	1	Front Projection	White	14'-0" wide x 8'-0" tall	Line Set or Legs	Yes

PROJECTION EQUIPMENT

- 1 – Christie D12WU-H Projector Mounted in Balcony Rail. 12,000 Lumens
- 2 – Crestron DM-TX-401-C Transmitter
- 1 – Crestron TSW-1060 Touch Screen
- 1 – Crestron SMPS3-4K-150 Presentation Switcher/Scaler

HOUSE ACOUSTIC TREATMENTS

The house has concrete walls with wooden and sheetrock sound baffles.
Adjustable acoustical curtains Located in multiple places in the house.
House acoustic ceilings are not adjustable.

ORCHESTRA SHELL

Orchestra Shell comprised of 8 towers and 3 clouds.
There are 3 preset positions for the orchestra shell depending on the size of performance
The acoustical cloud panels can be opened or closed, but not removed.
See drawings at the end of the document.

LINESET SCHEDULE

Lineset	Suspension	House Rep Purpose	Show Purpose	Distance from Plaster Line	Batten Length	Batten Type	Capacity	Purchase Line	In Trim	Out/Max Trim	Weight	Notes
39'-8"												
FC	Manual	Fire Curtain										
1	Manual	Main Border		2'5"	71'-0"	Single	1500	Single				
2	Manual	Main Curtain		3'-2"	71'-0"	Single	1500	Single				
3	Manual	General Purpose		3'-11"	71'-0"	Single	1500	Single				
4	Motorized	1st Electric		5'-5"	69'-0"	Double	2000	Motor				
5	Manual	General Purpose		6'-11"	71'-0"	Single	1500	Single				
6	Manual	General Purpose		7'-8"	71'-0"	Single	1500	Single				
7	Motorized	Orchestra Cloud #1		8'-5"	71'-0"	Truss	4000	Motor				
8	Manual	General Purpose		9'-11"	71'-0"	Single	1500	Single				
9	Manual	General Purpose		10'-8"	71'-0"	Single	1500	Single				
10	Manual	2nd Electric		12'-2"	69'-0"	Double	2000	Double				
11	Manual	General Purpose		13'-5"	72'-0"	Single		Single				
12	Manual	General Purpose		14'-2"	72'-0"	Single		Single				
13	Manual	General Purpose		14'-11"	72'-0"	Single	1500	Single				
14	Manual	General Purpose		16'-10"	72'-0"	Single		Single				
15	Manual	General Purpose		17'-6"	72'-0"	Single	1500	Single				
16	Manual	General Purpose		18'-1"	72'-0"	Single		Single				
17	Manual	General Purpose		18'-7"	72'-0"	Single		Single				
18	Motorized	Orchestra Cloud #2		20'-5"	71'-0"	Truss	4000	Motor				
19	Manual	General Purpose		21'-11"	71'-0"	Single	1500	Single				
20	Manual	General Purpose		22'-8"	71'-0"	Single	1500	Single				
21	Manual	3rd Electric		24'-2"	71'-0"	Double	2000	Double				
22	Manual	General Purpose		25'-4"	72'-0"	Single		Single				
23	Manual	General Purpose	October 2018			Single		Single				
24	Manual	General Purpose		27'-2"	72'-0"	Single	1500	Single				
25	Manual	General Purpose		27'-10"	72'-0"	Single		Single				
26	Manual	General Purpose		28'-6"	72'-0"	Single		Single				
27	Manual	General Purpose		29'-5"	71'-0"	Single	1500	Single				
28	Manual	General Purpose		30'-2"	71'-0"	Single	1500	Single				
29		Future Location										
30	Motorized	Orchestra Cloud #3		32'-5"	66'-0"	Truss	4000	Motor				
31	Manual	4th Electric		33'-11"	66'-0"	Double	2000	Double				
32		Future Location										
33		Future Location										
34	Manual	General Purpose	October 2018			Single		Single				
35	Manual	General Purpose		37'-8"	66'-0"	Single	1500	Single				
36	Manual	Cyclorama		38'-5"	66'-0"	Single	1500	Single				

ELECTRICAL

Company Switches

Location	Description	Rating	Output
Up Stage Left	LEX - Power Gate	100 Amp, 3 Phase, 208Y/120 VAC	16 series Cam-type receptacle and lug
Up Stage Left	LEX - Power Gate	200 Amp, 3 Phase, 208Y/120 VAC	16 series Cam-type receptacle and lug
Up Stage Left	LEX - Power Gate	400 Amp, 3 Phase, 208Y/120 VAC	16 series Cam-type receptacle and lug
Catwalk	LEX - Power Gate	200 Amp, 3 Phase, 208Y/120 VAC	16 series Cam-type receptacle and lug

Electrical Distribution

All circuits are 120VAC, 20A or 208Y/120VAC 20A

Dimmable 120v = Stage Pin connectors

Switched 120v = Edison, NEMA 5-15 straight

Switched 208v= L6-20 Connectors

LIGHTING

Dimming and control

The lighting control system is an ETC Gio*** or ETC Ion w/2 x 20 fader wing***

4 - ETC Sensor 3 dimmer racks.

ETC Paradigm Architectural/House Lighting System

iPad for Remote Focus Unit

House Lighting

Full house light control can be accessed by the console or remote panels. Limited house lighting control can be accessed by button panels located by the entrances. These can be locked out during performances.

Work Lighting

Work lighting can be accessed through the stage managers rack, console or remote panels.

Instruments***

133 ETC Source 4 ERS Bodies, 750w

20 – 50° Lens Tube

40 – 36° Lens Tube

40 – 26° Lens Tube

20 – 19° Lens Tube

14 – 14° Lens Tube

20 – 10° Lens Tube

92 – ETC Source 4 PAR, 750w (4 lenses available)

6 – Altman 3 Cell Cyc Lights

Follow Spot

2 – Lycian 1275, 1200w

Miscellaneous Accessories***

36 - "B" size Gobo holders (Source Four)

27 - "A" size Gobo holders (Source Four)

4 - "B" size Glass Gobo holders (Source Four)

16 – Female Edison to Male Stage Pin

6 – Male Edison to Female Stage Pin

22 – Two-Fers – Stage Pin

Multiple lengths of Cable – Stage Pin

8 – 13' Booms (Side Arms available)

11 – Top Hats for Source Four Ellipsoidals

8 – Top Hats for Source Four Pars

5 – Iris Units for Source Four Ellipsoidals

*** Items shared between Butler Hall and Babka Theater

Electrical Distribution/Lighting Positions

Location	Dimmer Circuits		Switched 120v		Switched 208v	
	Quantity	Circuits	Quantity	Circuits	Quantity	Circuits
Balcony Rail	14	197 – 210			2	551 – 552
FOH 1	3	295 – 297				
FOH 2	24	241 - 264			4	561 - 564
FOH 3	22	265 – 286			2	565 – 566
FOH 4 SL	4	287 – 290			1	567*
FOH 4 SR	4	291 – 294			1	568*
Box Boom SL	9	223 – 231	1	528	1	527
Box Boom SR	9	232 - 240	1	560	1	559
Anti Pro SL	6	211 – 216	1	554	1	553
Anti Pro SL	6	217 – 222	1	556	1	555
1 st Electric	38	31 – 68			4	523 - 526
2 nd Electric	34	69 – 102			4	527 - 530
3 rd Electric	34	103 – 136			4	531 - 534
4 th Electric	38	137 – 174			4	535 - 537
SL Deck Level Proscenium	4	1 - 4			1	513
SR Deck Level Proscenium	4	5 - 8			1	514
USL Deck Level	3	9 - 11	1	516	1	515
USC Deck Level	4	12 - 15	1	518	1	517
USR Deck Level	3	16 - 18	1	520	1	519
Grid Drop Box USL	4	179 - 182	1	542	1	541
Grid Drop Box DSL	4	175 - 178	1	540	1	539
Grid Drop Box USR	4	187 - 190	1	546	1	545
Grid Drop Box DSR	4	183 - 186	1	544	1	543
Orchestra Pit	6	191 - 196			1	538*
Orchestra Cloud #1	11	298 - 308				
Orchestra Cloud #2	10	309 - 318				
Orchestra Cloud #3	9	319 - 327				
SL Pin Rail	6	19 - 24			1	521*
SR Pin Rail	6	25 - 30			1	522*

* Doubled

AUDIO

Front of House

Location of Equipment	Manufacturer	Model	Description	Inventory	Notes
FOH					
	Allen & Heath	iLive T112	Mixer	1	
	Allen & Heath	iDR-32	Remote DSP Engine	1	
	Allen & Heath	PL-10	Remote Fader Plate	2	

Front of House PA, Power, & Speaker Processing

Type of Equipment	Manufacturer	Model	Notes	Main Hall Inventory
Speakers				
	EAW	AX396	L/C/R - bottom tier – Fixed Array	3
	EAW	AX364	L/R - top tier – Fixed Array	2
	EAW	AX122	Subwoofers – Fixed Array	2
	EAW	JF60z	Front Fill - Portable	8
	EV	ELX118P	Powered Subwoofer - Portable	2
Amplifiers				
	Crown	DCI4-1250	4 output (Mains)	1
	QSC	CMX2000V	Center and Front Fills	1

Monitor System – 8 Total Mixes Available

Type of Equipment	Manufacturer	Model	Notes	Main Hall Inventory
Amplifiers				
Permanent	QSC	CMX8000V	2 Amps with 2 Channels Each	4 Mixes
Portable***	QSC	RMX2450	2 Amps with 2 Channels Each	4 Mixes
Stage Monitors***				
	EAW	VRM12	12" Monitor	4
	Yamaha	CM15V	15" Monitor	6
	Yamaha	CM12V	12" Monitor	2

***Items shared between Butler Hall and Babka Theater

Microphone/DI/Misc.

Type of Equipment	Manufacturer	Model		Notes	Inventory
Mics / Direct Boxes***					
	Shure	ULXD4-H50	534-538 MHz	Wireless Receiver	9
	Shure	ULXD1		Body Pack Transmitter	9
	Shure	ULXD2/58		Hand Held Transmitter	9
	Shure	ULXP4-G3	470-506 MHz	Wireless Receiver	3
	Shure	ULX		Body Pack Transmitter	3
	Shure	ULX2/58		Hand Held Transmitter	3
	Shure	WL184		Lavaliere Mic	2
	Countryman	E6		Headset Mic	10
	Shure	WCB6		Micro-Lavalier Mic	6
	Shure	SM58			7
	Shure	Beta 58A			1
	Shure	SM57			4
	Shure	Beta 57A			2
	Shure	SM81		Cardioid Condenser	4
	Shure	Beta 52A		Kick Drum Mic	1
	Sennheiser	E604		Drum Mics	4
	Shure	PGA 98H		Instrument Mic	1
	Audio Technica	Pro 37		Cardioid Condenser	3
	Audix	M1255B		Condenser – Choir Mic	4
	Countryman	Isomax 2-H		Hanging Mic	3
	Rode	NT4		Stereo Condenser – Record Mic	1
	Rode	NT1		Large-diaphragm Condenser	2
	Crown	PCC 160		Floor Mic	4
	Whirlwind	PCDI		Stereo DI - Passive	2
	Whirlwind	Director		DI Box – Passive	5
	Whirlwind	Director-II		Dual DI box - Passive	1
	Behringer	Ultra DI		DI Box - Active	1

Mic Stands, cables and snakes also available

*** Items shared between Butler Hall and Babka Theater

Audio Input/Output Locations

Location	Mic Lines	Tie Lines	Speaker Lines	Ethernet	Video	Intercom
DSR Panel	1 - 12	9 - 12	1 - 4	1 - 6	1 - 2	A B C D
DSL Panel	13 - 24	13 - 20	5 - 8	7 - 10	44 - 47	A B C D
US Panel	25 - 28	21 - 24	9 - 12	11 - 14	3 - 7	A B C D
Orchestra Pit	29 - 40	25 - 28	13 - 16	15 - 18	8 - 9	A B C D
FOH 1	41 - 44	29 - 30	17 - 18	25 - 26	14 - 15	A B C D
Grid	45 - 48	39 - 40	27 - 28	35 - 36	24 - 25	A B C D
FOH 2	49 - 50	31 - 32	19 - 20	27 - 28	16 - 17	A B C D
FOH 3	51 - 52	33 - 34	21 - 22	29 - 30	18 - 19	A B C D
FOH 4 HL	53 - 54	35 - 36	23 - 24	31 - 32	20 - 21	A B C D
FOH 4 HR	55 - 56	37 - 38	25 - 26	33 - 34	22 - 23	A B C D
House Left - Vineyard			29			
House Right - Vineyard			30			
Follow Spot Booth		45 - 46			38 - 39	A B C D x 3
Backstage Corridor SL		43 - 44			36 - 37	A B C D
Backstage Corridor SR		41 - 42			34 - 35	A B C D
Stage Manager Panel SR					40 - 43	A B C D
Balcony Face				37 - 42	28 - 29	
Balcony Rear				46	32 - 33	
Balcony HL				43	26 - 27	
Balcony HR				45	30 - 31	
Projector Slot					56 - 60	
Control Room - Center		1 - 8		19 - 24	19 - 24	A B C D
Control Room - HR					48 - 51	A B C D
Tech Table					52 - 55	A B C D
Band Storage						A B C D
Equipment Storage						A B C D
Pin Rail SR						A B C D
Dimmer Room						A B C D
Loading Bridge						A B C D
Scene Shop						A B C D
Costume Shop						A B C D
Pin Rail SR						A B C D
Pin Rail SR						A B C D

Intercom/ Paging System

Components***

Type of Equipment	Manufacturer	Model	Notes	Inventory
Main Station	Clear-Com	MS704	1 main station is portable	2
Remote Station	Clear-Com	RM704		2
Wired Belt Pack	Clear-Com	RS601		8
Double Muff Headset	Clear-Com	CC-60		2
Single Muff Headset	Clear-Com	CC-95		6
Gooseneck Mic	Clear-Com	GN18	For paging system	2
Handset	Clear-Com	HS-6		4

Paging System***

Integrated into the intercom system is the paging system. There is a monitor to each location, and each location has an independent volume control. The page mic is located stage right on the stage managers rack or in the control booth. The page mic will override the independent volume control in each room, but not the master switch.

Paging / Program Locations***

AV Storage	Follow Spot Booth
Large Dressing Room	Stage Equipment Storage
Small Dressing Room	Loading Dock
Makeup Room	Control Booth
Costume Shop	Corridor
Scene Shop	Costume Shop
Green Room	Black Box Control Room
Dimmer Room	Black Box Dimmer Room
Instrument Storage	Black Box Amp Room

Assisted Listening System

House management maintains control of ALD receivers and distributes them upon request.

Type of Equipment	Manufacturer	Model	Notes	Main Hall Inventory
Assisted Listening				
	Listen	LT-800-072	Transmitter	1
	Listen	LT-300-072	Receiver***	35
	Listen	LA-164	Ear Piece***	35
	Listen	LA-166	Neck Loop***	9

*** Items shared between Butler Hall and Babka Theater

MISCELLANEOUS

Pianos

- 1 - Steinway & Sons Concert Grand - Model D - 9'-0"
- 1 - Steinway & Sons Grand – Model S – 5'-1"
- 1 – Yamaha C3 Grand - 6'-1"
- 1 – Yamaha GC1 Grand - 5'-3"
- 1 – Yamaha U1-Silent Upright

Chairs / Music Stands***

- 97 - Wenger musician's chairs
- 50 - Manhasset music stands
- 10 - Music Stand lights

Staging***

- 8 – 4'x8' Staging Concepts Stage Decks (Black Deck Finish)
- 60 – 3'-6' Staging Concepts Stage Decks (Black Deck Finish)
- 15 – “Pie” pieces (different sizes)
- 44 – 8” Legs
- 72 – 14” Legs
- 44 – 16” Legs
- 44 – 24” Legs
- 72 – 28” Legs
- (4 legs needed for each deck)

Skirting for Staging***

- 6 – 8” Tall x 8’ Long
- 8 – 16” Tall x 8’ Long
- 4 – 24” Tall x 8’ Long

Other***

- 6 – 30” Wood Backless Stools (Black)
- 1 – Clearsonic 5 Section Drum Shield 24” x 66”
- 1 – Blizzard Atmosfear Tour HZ Hazer
- 1 – 20” Mirror ball with 3 RPM motor

BACKSTAGE

Dressing Rooms***

- 2 Dressing Rooms with counters, mirrors, toilets, sinks and showers
- 1 Makeup room located between the dressing rooms equipped with counters, mirrors, outlets, sinks, and mirror lights

Laundry***

- 1 – Jiffy Steamer J-4000
- 2 – Iron
- 2 – Ironing Board
- Washer and Dryer needs can be accommodated on campus with advance notice

Green Room***

The Green Room is an open lounge located between the Babka Theatre and Butler Hall backstage.

*** Items shared between Butler Hall and Babka Theater

STAGE DIMENSIONS

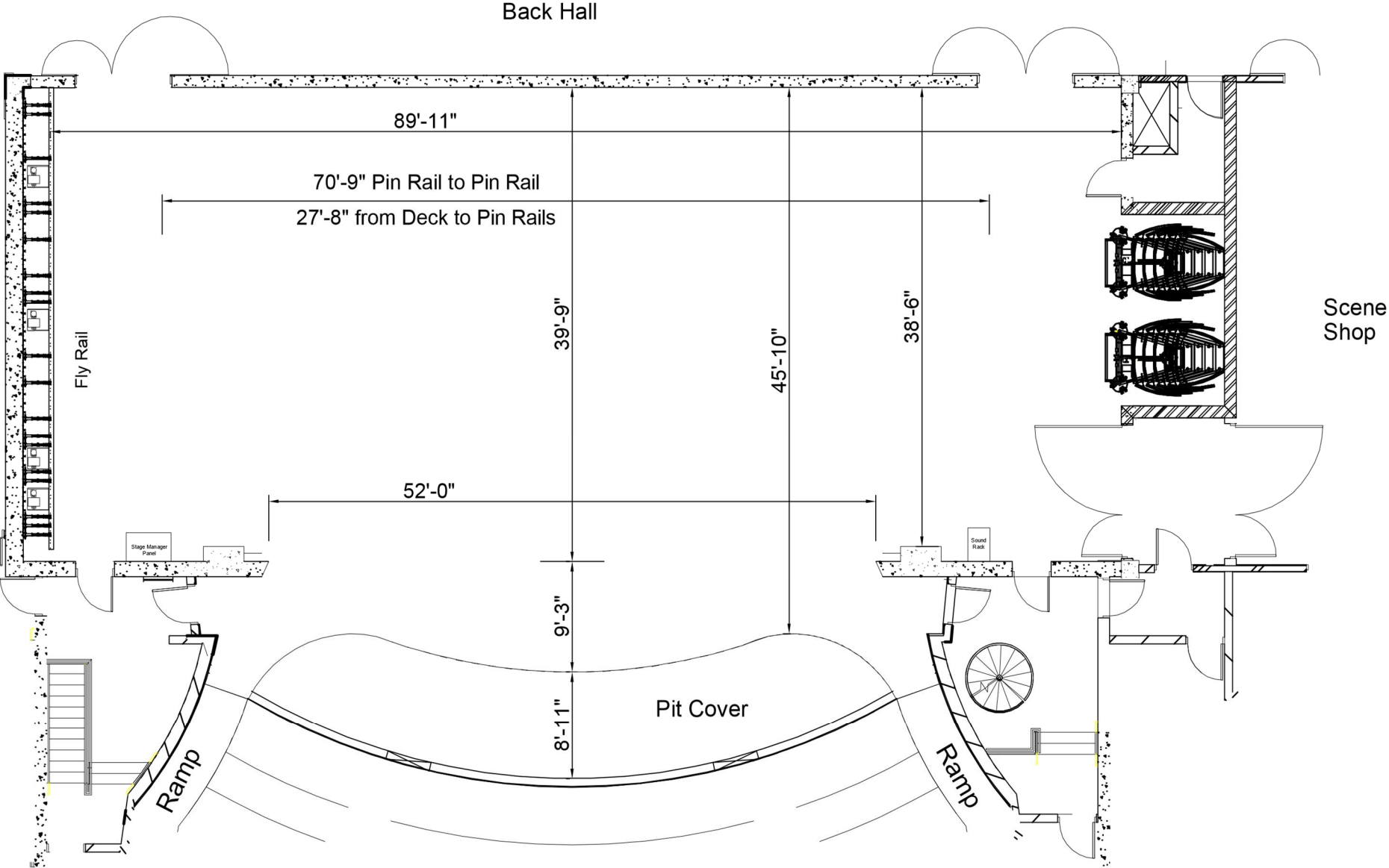

ORCHESTRA SHELL POSITIONS

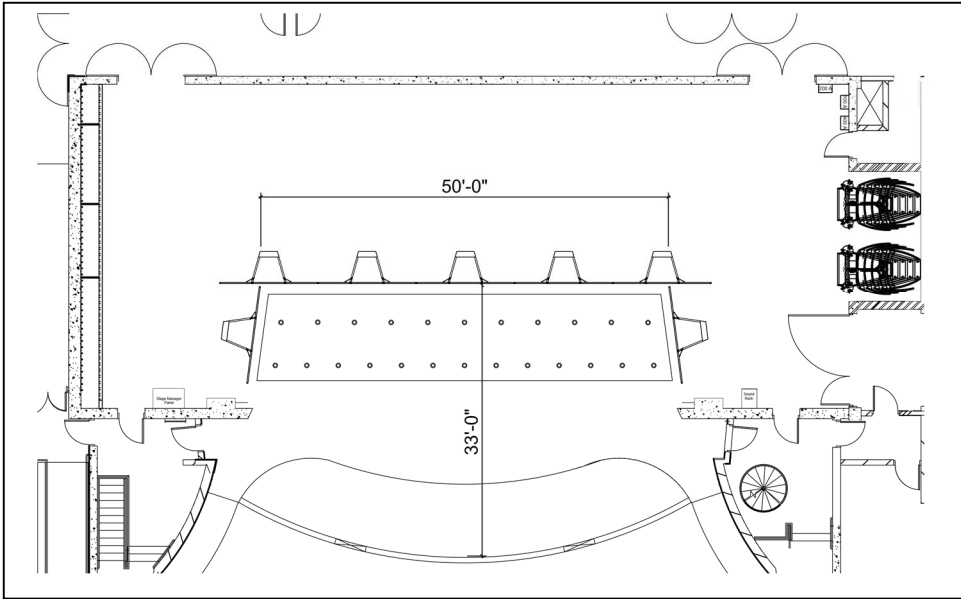

Position 1

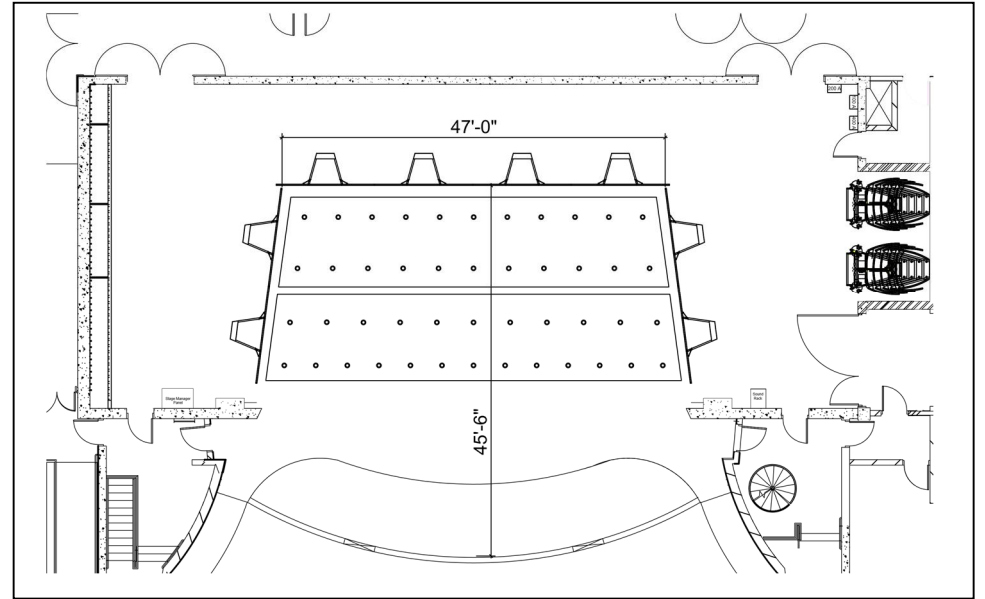

Position 2

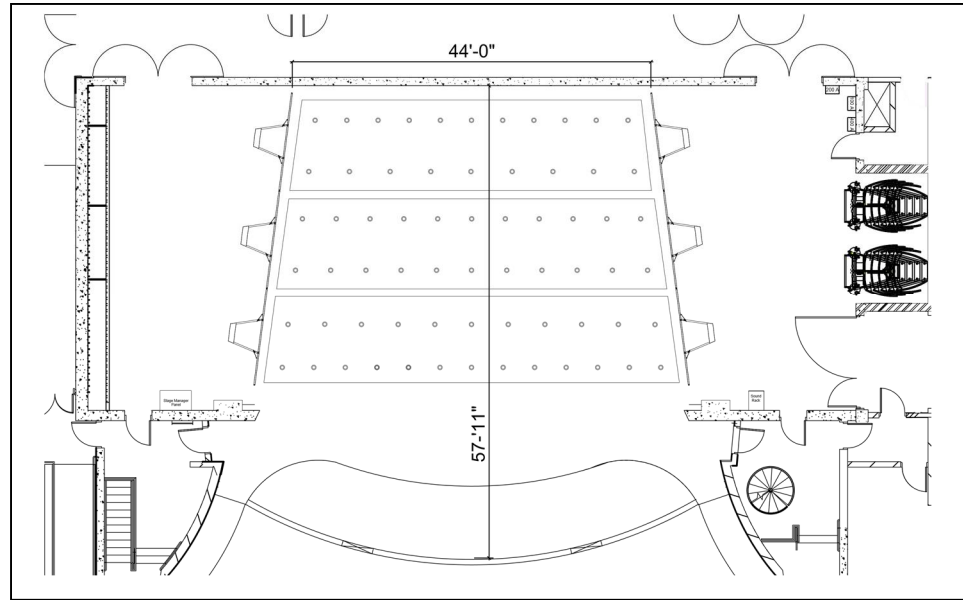

Position 3

FIRST FLOOR LAYOUT

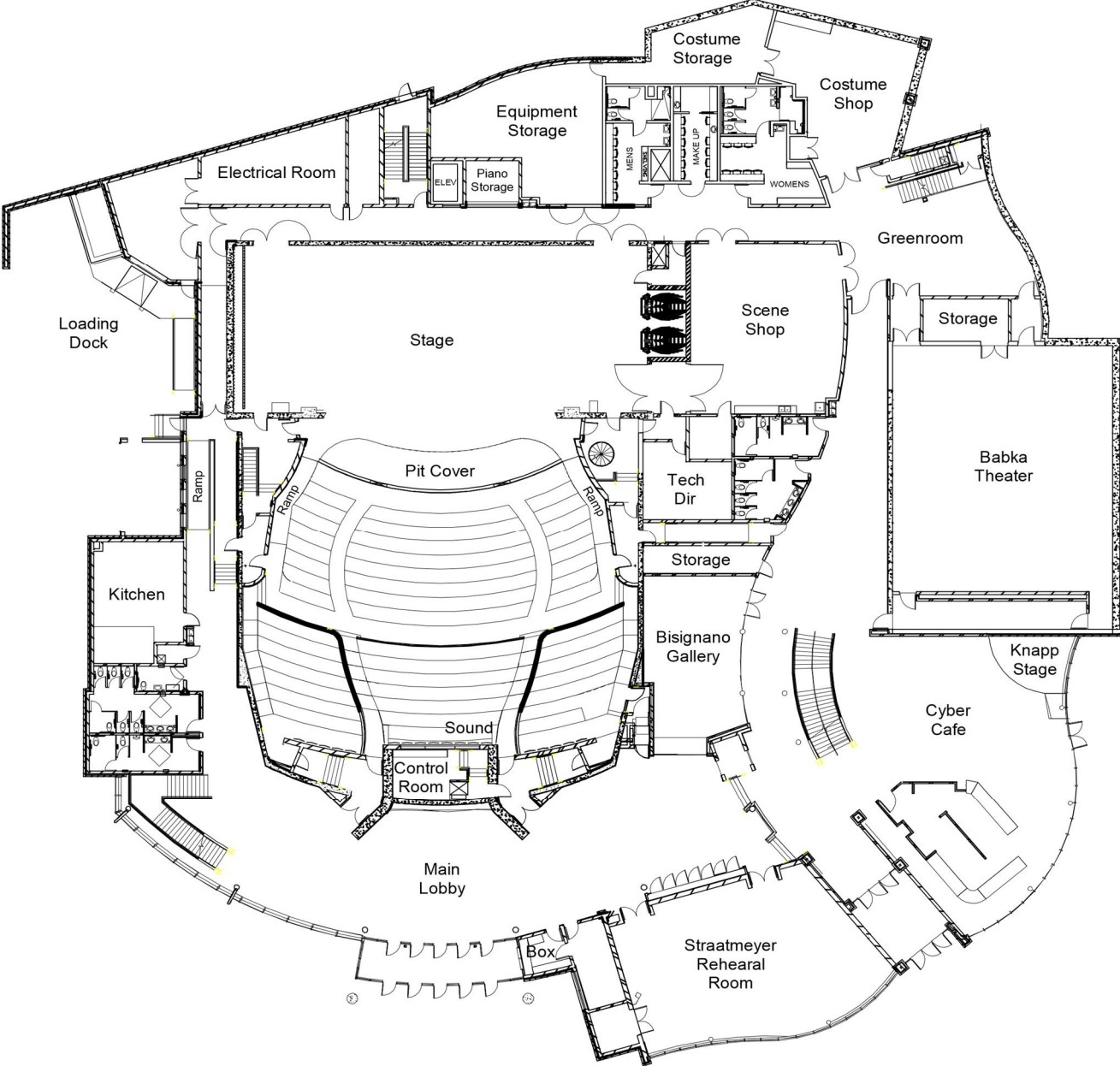

RIGGING

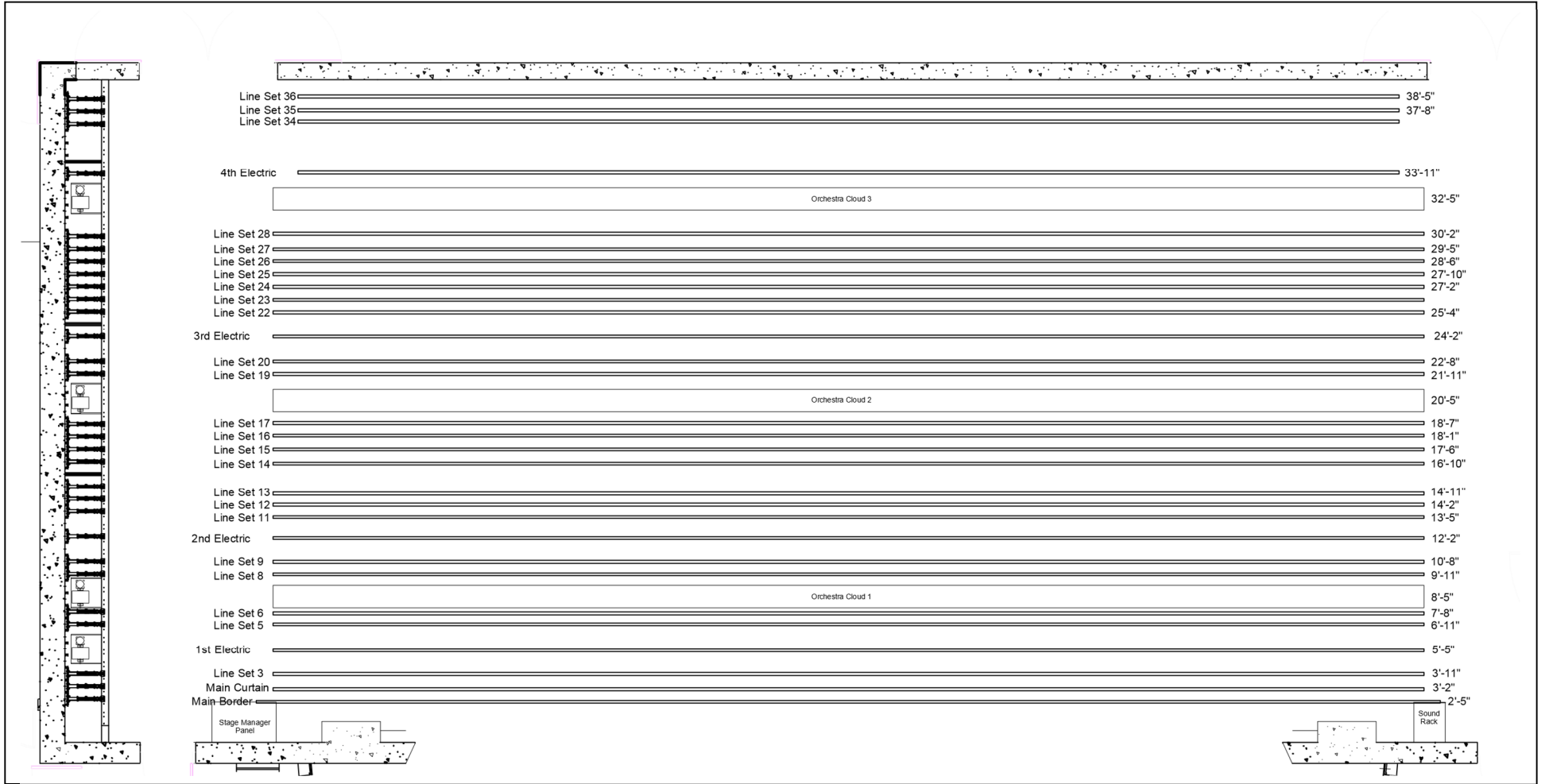

CROSS SECTION

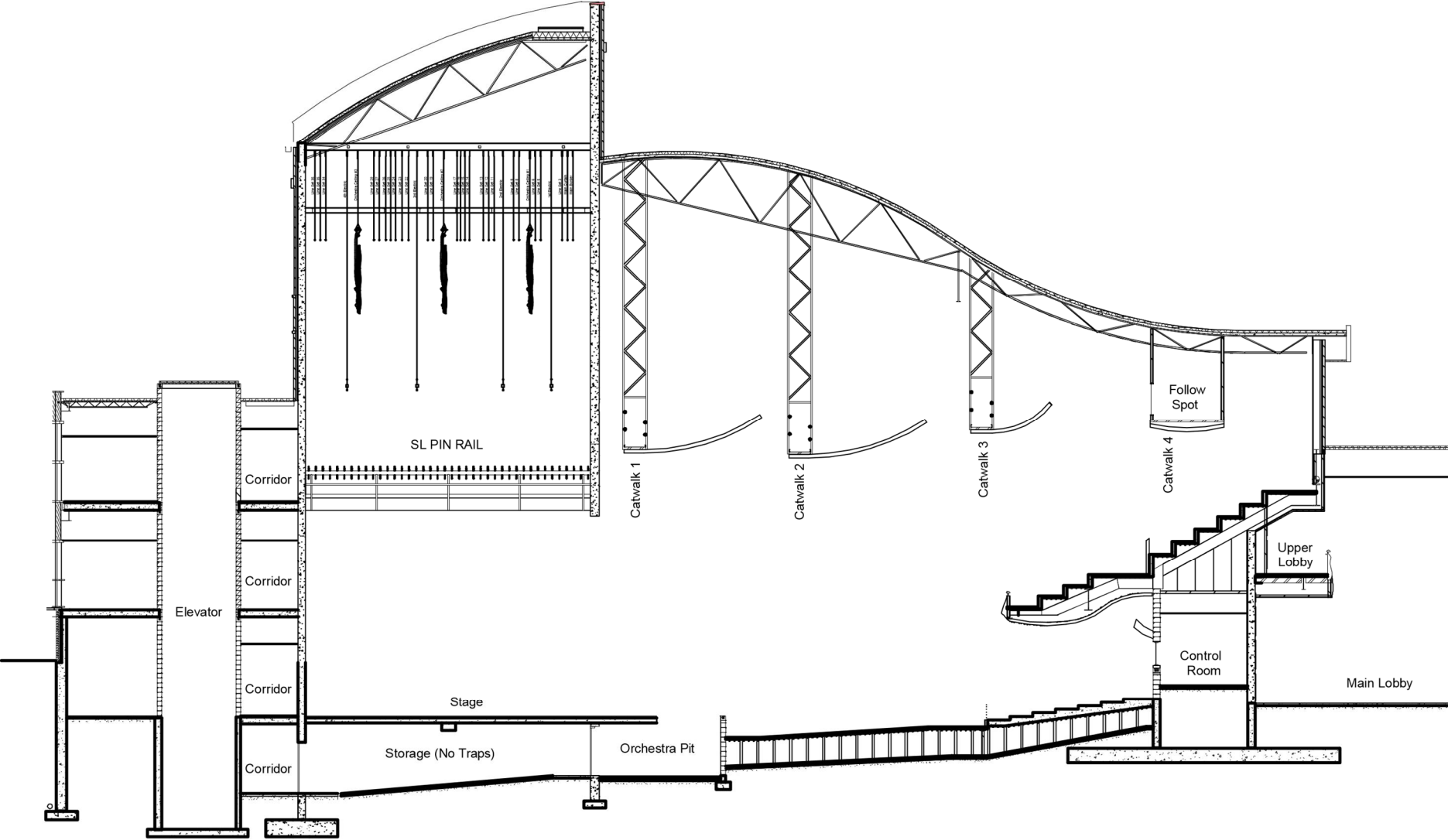

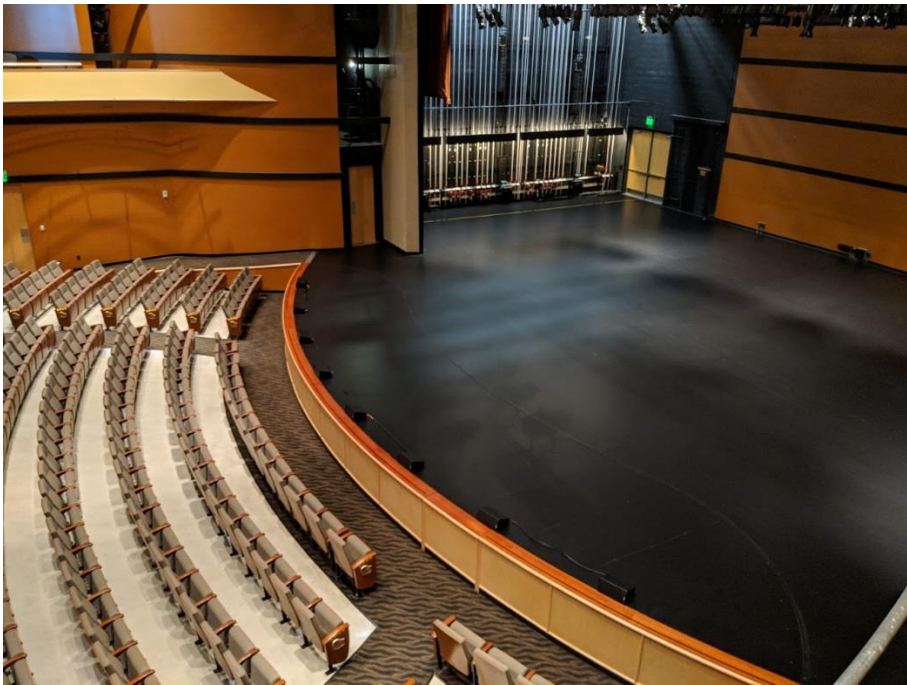
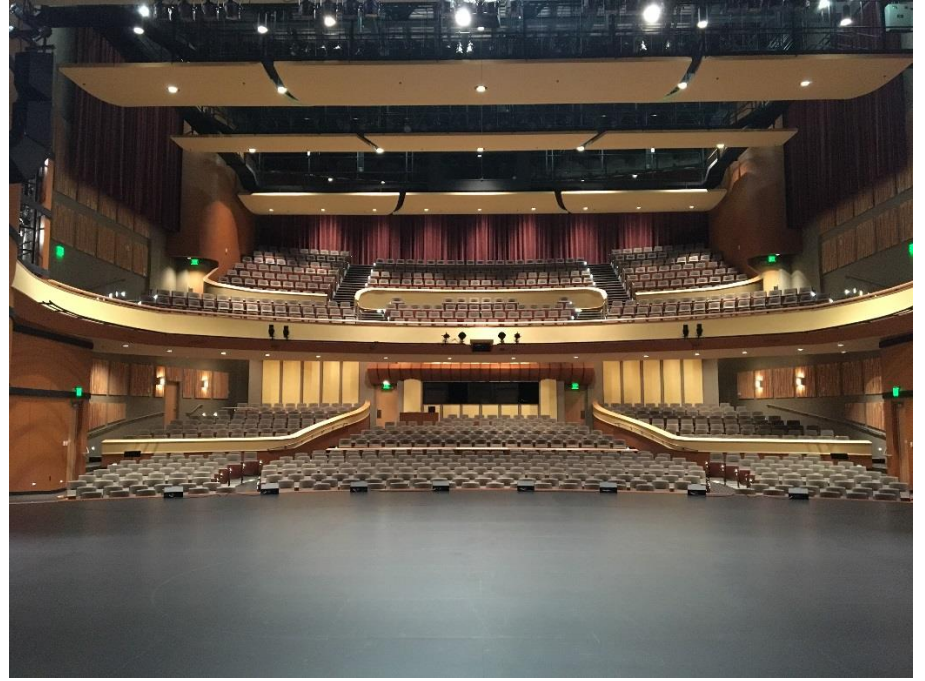

Hotels (in alphabetical order, no recommendation implied)

Best Western Plus Dubuque Hotel & Conference Center 3100 Dodge St, Dubuque, IA	(563) 557-8000
Country Inn & Suites By Carlson Dubuque, IA 1315 Associates Dr, Dubuque, IA	(563) 583-2500
Days Inn Dubuque 1111 Dodge St, Dubuque, IA	(563) 583-3297
Grand Harbor Resort & Waterpark 350 Bell St, Dubuque, IA	(563) 690-4000
Hampton Inn Dubuque 3434 Dodge St, Dubuque, IA	(563) 690-2005
Hilton Garden Inn Dubuque Downtown 1801 Greyhound Park Rd, Dubuque, IA	(563) 585-5200
Holiday Inn Dubuque 450 Main Street Dubuque, IA 52001	(563) 556-2000
Hotel Julien Dubuque 200 Main St, Dubuque, IA	(563) 556-4200
Redstone Inn & Suites 504 Bluff St, Dubuque, IA	(563) 582-1894
Super 8 Dubuque/Galena Area 2730 Dodge St, Dubuque, IA	(563) 582-8898

Medical (in alphabetical order, no recommendation implied)

[Finley Hospital](#) - .4 Miles (563) 582-1881
350 N Grandview Ave, Dubuque, IA

[Mercy Hospital](#) - 1.3 Miles (563) 589-8000
250 Mercy Dr, Dubuque, IA

Taxi (in alphabetical order, no recommendation implied)

#1 Green Cab	(563) 495-4444
A1 Taxi & Delivery Premier Services	(563) 582-1818
A Classy Taxi	(563) 495-7222
C M Cab Co	(563) 556-1303
E & R Taxi	(563) 564-9938
E-Z Taxi Service of Dubuque	(563) 582-3999
Starlight Mini Bus & Limousine	(563) 552-2028
Starlight Cab Co	(563) 556-6666

Laundry/Drycleaners

Courtesy Cleaners 535 Hill St, Dubuque, IA	(563) 583-5332
Courtesy Cleaners 3398 Kennedy Cir, Dubuque, IA	(563) 583-3999
Premier Linen & Uniform 461 W 9th St, Dubuque, IA	(563) 583-9153